

# ***HADK-T600UCQ-HD***

## ***AIR HAMMER (QL60)***

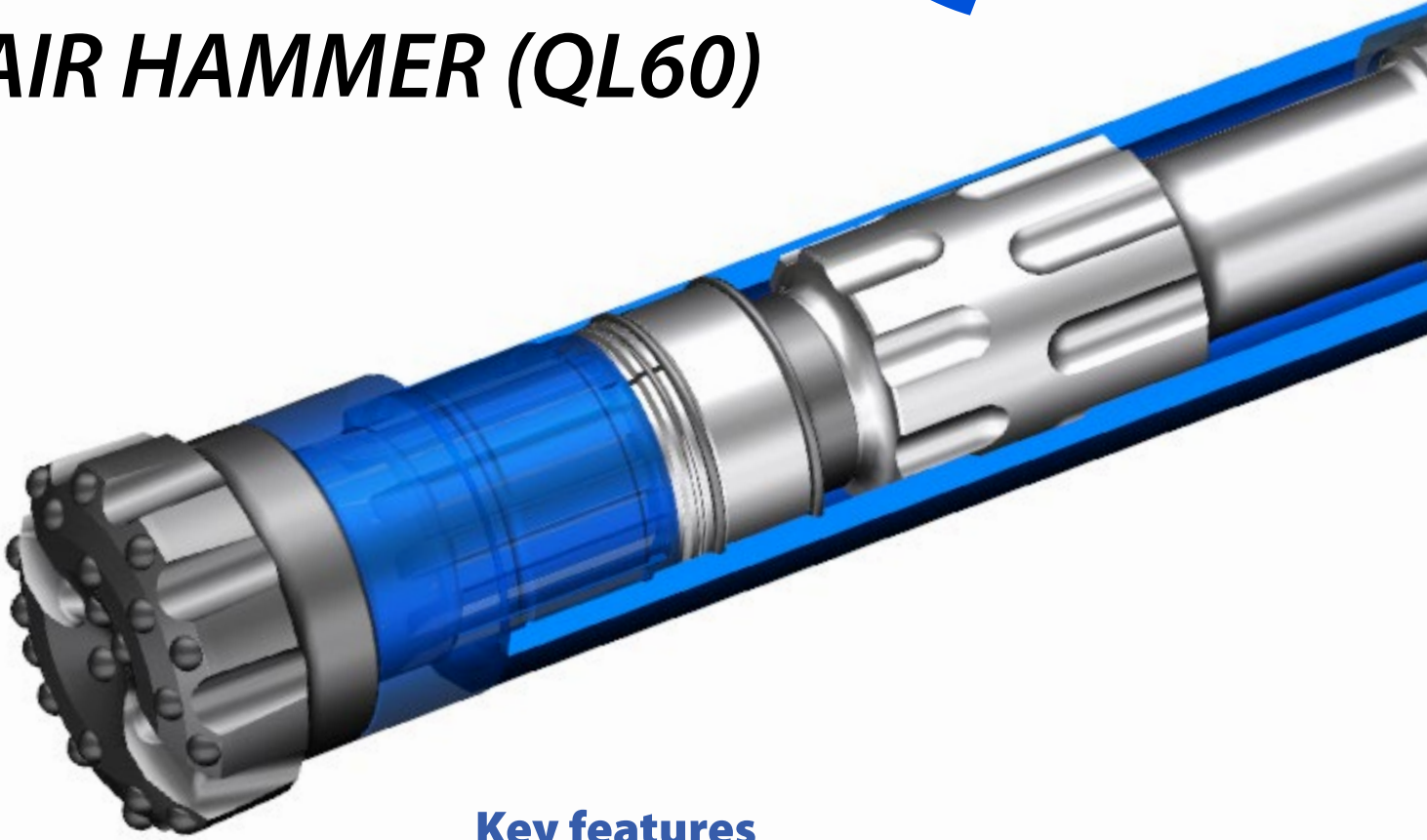

### **Key features**

- Innovative & simple design for easy eco kit maintenance
- High frequency design for fastest penetration rates for Mining, Water Well and Construction
- Elimination of Bio Tube for increased reliability
- Premium alloys & treatment used for longer lasting tools

## Parts List (QL60)

NO	Part Name	Qty	Part Number
1	Top Sub	1	HPDK-TUC6002-HD
2	Top Sub O-Ring	1	
3	C.V. Spring	1	HPDK-TUC6004
4	Check Valve	1	HPDK-TUC6003
5	C.V. Spring	1	HPDK-TUC6004
6	Air Distributor	1	HPDK-TUC6010
7	Cylinder	1	HPDK-TUC6012
8	Piston	1	HPDK-TUC6014
9	Wear Sleeve	1	HPDK-TUC6001-HD
10	Bearing	1	HPDK-TUC6020
11	Bit Retaining Ring	1	HPDK-TUC6018-Q
12	Bit Ret O-Ring	1	
13	Drive Sub	1	HPDK-TUC6022-QHD
	Sealkit (Items 2, 12)	1	HPDK-TUC60SEALKIT
	Complete Hammer		HADK-600UCQ

### Dimensions & Weights

Top Sub	3 ½" API REG PIN
OAL (in / mm)	43.5 / 1105
OD Range (in / mm)	5.59 / 142
Weight w/o bit (lbs / Kg)	216 / 98
Piston Weight (lbs / Kg)	52 / 24

### Drilling Parameters

Working Pressure (PSI / Bar)	150-350 / 10.3-24.1
Application Bit (in / mm)	6.7 / 152-178
Feed Force (FT-lbs / M-Kg)	1300-4500 / 180-622
Rotation Speed	12-40 RPM
Rotation Torque (FT-lbs / M-Kg)	2400 / 332
Frequency (blows / min)	1455

### Air Consumption

PSI	BAR	CFM	CuMtr/Min
150	10.3	340	12.3
250	17.2	660	18.8
350	24.1	970	25.5

## Exploded view

